

CONTROL OF SUBSTANCES HAZARDOUS TO HEALTH - (Technical background material for the NERC COSHH software package)

VERSION NUMBER: 1.7

DATE OF ISSUE: 10 August 2006

INTRODUCTION

The primary function of the **Control of Substances Hazardous to Health Regulations (2002) and amendments to 2005** is to ensure that employers carry out an assessment to:

- Identify substances **hazardous** to health used in any aspects of the work
- **Demonstrate** readily to him/herself and to others that **all factors pertinent to the work** have been considered
- Demonstrate that a **valid judgement** has been reached about the **risk**
- Identify steps needed to **achieve** and **maintain** adequate control
- Decide on the need for workplace **monitoring** and/or **health surveillance**.

The requirement is for a “**suitable and sufficient**” assessment; this is defined as follows:

- *“An assessment can be considered suitable and sufficient if the detail and expertise with which it is carried out are commensurate with the nature and degree of risk arising from the work, as well as the complexity and variability of the process.”*

This policy and procedure document gives guidance on how NERC sites should deal with the key areas highlighted in red above and achieve the defined suitable and sufficient assessment.

All injuries, and near misses, must be entered in the local Accident Reporting System ; accidents and incidents involving injury or ill-health caused by ‘substances’ may be reportable under RIDDOR.

The Procedure covers:

- Chemicals bought from suppliers as materials for use in research
- Materials of all kinds brought in from the field (soil, rocks, sediment etc.)
- Dusts generated on or off site during the course of working ([see definition later](#))
- Mixtures of the above
- Products containing chemicals used on site (cleaning materials, paints etc.)



It excludes:

- **Biological materials brought in from the field or obtained from organisms held on site**
- **Biological agents....**

which, although covered by the COSHH Regulations, are dealt with in a separate Procedure.

CONTENTS:

Operational procedure

Roles and responsibilities

System flow diagram

What might go wrong? – probable sources of system and individual failure

Management, monitoring and auditing

Appendices:

Appendix I: Summary of Regulations

Appendix II: Sources of information on the hazards of chemicals and other substances

Appendix III: EU Risk Phrases and hazard classification

Appendix IV: Estimation of exposure to refine the basic COSHH assessment

Appendix V: General information on first aid following exposure to chemicals

Appendix VI: NERC guidance on the safe use, maintenance and testing of laboratory fume cupboards

Appendix VII: Emergency services and COSHH

Appendix VIII: Sources of further information

NOTE: The following are excluded from the COSHH Regulations:

- Lead – in so far that the Control of Lead at Work Regulations (1998) apply
- Asbestos – in so far that the Control of Asbestos at Work Regulations (2002) apply
- Substances hazardous to health solely as a consequence of their: radioactive, flammable or explosive properties or solely because they are at high or low temperature or high pressure. **Despite this exclusion, this Procedure covers all physical properties of substances (flammability, explosivity, asphyxiation potential, risk from high pressure, low temperatures etc.). The requirements of the Dangerous Substances and Explosive Atmospheres Regulations (2002) for safety assessments of such substances are, therefore, met by this Procedure.**

COSHH excludes work done on board ship; however, the following Procedure will be adequate to cover the requirements of the marine legislation on the risk assessment of chemicals.

Introduction:

The **Control of Substances Hazardous to Health Regulations (2002)** require a “suitable and sufficient” hazard and risk assessment of all **substances** used in the workplace. Substances include:

- Chemicals bought from suppliers as materials for use in research
- Materials of all kinds brought in from the field (soil, rocks, sediment etc.)
- Dusts generated on or off site during the course of working ([see definition](#))
- Mixtures of the above
- Products containing chemicals used on site (cleaning materials, paints etc.).

The following are also included in COSHH but are dealt with in a separate Procedure:

- Biological materials brought in from the field or obtained from organisms held on site
- Biological agents

* Dusts fall under the definition of substances hazardous to health if:

- They have a chemical nature which would attract a “toxic, very toxic, harmful, corrosive or irritant” classification
- Their chemical constituent(s) attract an occupational exposure standard
- They are dusts of any kind other than those above and are present at a concentration in air \geq : **10 mg/m³** as a time weighted average over 8 hours for **total inhalable dust** or **4 mg/m³** as a time weighted average over 8 hours for **respirable dust**

A “**suitable and sufficient**” assessment can be defined as follows:

- “An assessment can be considered suitable and sufficient if the detail and expertise with which it is carried out are commensurate with the nature and degree of risk arising from the work, as well as the complexity and variability of the process.”

Management involvement

HSE lists the requirements from management for the main elements of COSHH as follows:

Duty of employer relating to:	Duty for the protection of: Employees	Duty for the protection of: Other people on the premises	Duty for the protection of: Other people likely to be affected by the work
Assessment	Yes	So far as is reasonably practicable	So far as is reasonably practicable
Prevention or control of exposure	Yes	So far as is reasonably practicable	So far as is reasonably practicable
Use of control measures and maintenance, examination and test of control measures	Yes	So far as is reasonably practicable	So far as is reasonably practicable
Monitoring exposure at the workplace	Yes, where requisite	So far as is reasonably practicable	No
Health surveillance	Yes, where appropriate	No	No
Information, training etc.	Yes	So far as is reasonably practicable	No

The management of NERC sites have an absolute requirement to assess and control the risks for their own employees; provision of information and training is obligatory. Under normal circumstances, such assessment and control will also protect others working on the premises; where contractors are working on the maintenance or removal of equipment (**particularly fume cupboards and other ventilation or sewage treatment plants/drains**) likely to be contaminated with hazardous substances **it is a requirement that they be informed of the hazards and risks.**

It is a requirement on the contractor to inform the site management of any hazardous substances to be used during the course of the work being carried out; however, contractors should be asked about this to ensure that NERC's duty of care to its own employees is satisfied. Management is specifically required to ensure that **members of the emergency services are aware of substances present on the premises which might offer significant risks to their health (Appendix VII).**

ASSESSMENT UNDER COSHH IS COMPLEX; THE DETAILED DESCRIPTION FOLLOWING IS FOR TECHNICAL INFORMATION. SOFTWARE ACCOMPANYING THIS PROCEDURE WILL GUIDE YOU THROUGH THE PROCESS AND PERFORM THE NECESSARY CALCULATIONS.

Assessment: Hazards associated with **all** substances brought onto, or used, on sites **must be identified**; risks arising from these hazards **must be addressed**. Sources of information to achieve hazard identification are given in [Appendix II](#).

Chemicals and other substances transferred from their original packaging to other containers must be adequately labelled. If the hazard classification is low, simply labelling with chemical name is adequate (recognised abbreviations are also acceptable). If hazard classification is higher, some indication of the hazard should also be placed on secondary containers.

Risk assessment for COSHH cannot be conducted using the standard risk assessment procedures required by the **Management of Health & Safety at Work Regulations (1999)** and set out for NERC in **Risk assessment and risk management; NERC Procedure Number 12**. HSE gives specific guidance on how to conduct risk assessments under COSHH in **"COSHH Essentials" (HS(G) 193; HSE Books, 1999)**; the technical basis for this risk assessment system can be found in **"Technical basis for COSHH Essentials" (HSE Books, 1999)**. This guidance is written with industry (particularly small to medium sized enterprises) in mind and has been modified in this Procedure to suit the research environment. However, the main elements of the HSE-recommended risk assessment have been retained and extended. The reason that a different approach is needed for COSHH than all other regulations is that the detailed toxicological information, and exposure assessment, required to 'quantify' risk is seldom available. Basic COSHH 'risk' assessments move directly from **hazard identification** to **risk reduction** without the usual true assessment of risk.

"COSHH Essentials" introduces a classification of chemicals based on hazard as indicated by the standard **EU Risk Phrases** given in [Appendix III](#) (these are unfortunately named since they indicate **hazard** of substances and not **risk**). The EU Risk Phrases are assigned to chemicals and other substances under **CHIP (Chemicals (Hazard Information and Packaging for Supply) Regulations 2002)**. A look-up table is used to assign classification categories based on these Risk Phrases ([Appendix III](#)). **Note that the table used in this Procedure covers all Risk Phrases, including those covering the physical hazards (such as flammability and explosive properties) excluded from the HSE version; it also covers the "environmental Risk Phrases" relevant to disposal of waste substances.**

Different **routes of exposure** are handled differently by "COSHH Essentials":

- The main classification system for hazard (**A to E**) is based on the **inhalation route**
- A secondary classification system (**S**) covers those substances which are absorbed through the **skin** and/or are **irritating to the skin or eyes**
- Ingestion is assumed to be always unintentional (=accidental) and/or conscious (=known). The ingestion route is, therefore, covered only under the emergency/first aid requirements of COSHH.

Hazard assessment is limited to the inhalation and dermal routes because such exposure will be unwitting and unknown by workers handling the substances.

In addition to the hazard classification, the COSHH risk assessment may take account of quantity in use for the particular application and the volatility/dustiness of the substance ([Appendix IV](#)).

NOTE: There is a specific requirement under the Management of Health & Safety at Work Regulations (1999) for the assessment of risk to women of child bearing age. In Appendix III, those risk phrases associated with hazards to the unborn child are highlighted as "reproductive toxins" in the special classification column of the table.

Prevention or control of exposure

The outcome of the basic COSHH risk assessment using this scheme is a recommendation of the degree of containment necessary for the safe use of the substance:

- General ventilation (=use of the substance on an open bench)
- Local ventilation (such as local hoods with [filtered] or without [vented to outside of the building] recycling etc.)
- Containment allowing the possibility of minor or occasional breaches of containment (fume cupboards)
- Special containment which effectively reduces staff exposure to zero.

Additionally, personal protective equipment (PPE) will be recommended for substances carrying classification S to protect skin and/or eyes; **this is the one occasion where PPE is a requirement irrespective of other risk management in place.**

This Procedure recommends a stepwise approach:

- A. Can the substance be used entirely within the containment recommended by an assessment based solely on its hazard classification, without taking account of quantity in use and/or the nature of the substance (dusty or volatile)? [Appendix III](#)
- B. If not, does the small quantity/low volatility or dustiness lead to an assessment of the risk as low? [Appendix IV](#)
- C. If not, an advanced risk assessment procedure is needed which makes some estimation of exposure and may require specific expertise on the toxicology/toxicokinetics of the substance being assessed.

If the recommended containment can be achieved within the desired experimental or research design, this forms the “suitable and sufficient” risk assessment under COSHH (conditions A or B above). If condition C applies, the risk assessment process must continue until “the detail and expertise with which it is carried out are commensurate with the nature and degree of risk arising from the work, as well as the complexity and variability of the process.” This will always require input from relevant experts.

Use of control measures and maintenance, examination and test of control measures

Management systems are needed to ensure that the control measures indicated in the risk assessment are implemented. This should be managed using the “active monitoring” techniques outlined in **Successful health & safety management (HSG65, HSE Books 2000)**. On many NERC sites there will be large or very large numbers of COSHH assessments. Management systems will be unable to check the operation of all of these on a regular basis; prioritisation of management checks should be on a risk basis. Risk reduction measures for those COSHH assessments indicating highest hazard or risk should be given priority.

Since the major risk reduction/risk mitigation methods under COSHH are reliant on containment and/or ventilation systems, **maintenance of these engineering controls is essential on a regular basis**. Local management must ensure that such maintenance is relevant, conducted by competent persons **and recorded**. Guidance on test methods, with required results on face velocity and containment to meet NERC standards for fume cupboards are given in [Appendix VI](#). The results of such testing **must be recorded**.

Maintenance of fume cupboards, extract and ventilation ducting will require access to all parts of the systems by engineers. **All fume cupboards and other extract/ventilation systems must have records attached which inform engineers of the nature and hazards of the chemicals extracted.**

Monitoring exposure at the workplace and health surveillance

Substances may have occupational exposure limits assigned to them. These limits were formerly of two types and older Safety Data Sheets will still refer to them:

- **Occupational Exposure Standards (OESs)** These are set at a level of exposure, which available evidence indicates will not cause damage to health, even over long periods. The value is determined scientifically from the toxicology and applies “uncertainty factors” (sometimes called “safety factors”) to extrapolate to lifetime exposures.
- **Maximum Exposure Limits (MELs)** These are set for substances which may cause the most serious health effects, such as cancer and occupational asthma, and for which “safe” levels of exposure cannot be scientifically determined. The value is based on the

best practicable technology available for exposure reduction.

In 2005, both OES and MEL were replaced by **WELs (Workplace Exposure Limits)**. WELs could have been derived by either of the two methods outlined above.

A list of all substances attracting a WEL is published by HSE in EH40 – available on the web and as a hard copy from Safety Advisers. Note that if a substance is not listed it does not mean that it is safe, just that it has not yet been considered.

If a WEL is listed for substances you are using, you **must** consider whether you need to monitor the levels in the workplace air. You might also conclude that monitoring is necessary for non-listed substances. Normally, this decision would be based on:

- The quantity of substance being used
- The physical nature of the substance being used (is it likely to lead to exposure via the inhalation or dermal routes?)
- The degree of containment you have in place and its reliability in the particular use of the substance.

For substances used in quantity (for example solvents in a chemical analytical laboratory, formaldehyde used as a biological preservative or rock/soil samples processed in bulk in a sample preparation area), monitoring is essential on a regular basis. A genotoxic carcinogen used in very small quantities, in a physical form unlikely to lead to exposure and enclosed in a fume cupboard would probably not warrant monitoring despite its high hazard classification. Judgement is needed and you should record why you decided to monitor or not. Seek advice if you are uncertain.

Note that if there is a failure in the containment/extraction system which forms the basis for your safe system of work, monitoring of the likely resultant exposure of staff should be part of your management of the system failure.

If monitoring is put in place, you should decide on its frequency and on the level of competence required to carry it out. **Records of all monitoring must be kept; since these will be required if Inspectors are assessing likely health effects over long periods or a legal case is brought against the organisation, the records must be archived for the full working life of individuals (in practice a period of 40+ years).**

In some cases, health surveillance is needed in addition to monitoring of exposure. For some substances, biological monitoring of exposure is also a better indicator than monitoring the workplace air. In order to carry out either health surveillance or biological monitoring, you **must have an occupational health provider in place.**

For work done in NERC, there is no specific automatic requirement for health surveillance in COSHH (the Schedules within the Regulations list only industrial applications of substances). However, area of work likely to require health surveillance in NERC include:

- Exposure or possible exposure to dusts on a regular basis
- Exposure or possible exposure to allergens, including animal fur or feathers.

Information and training. Under COSHH, there is a specific requirement to provide staff with information on:

- The **nature and degree of risk** associated with any substances they use during their work
- The **control measures adopted** for use of particular chemicals, **the reasons for these** and training on how to use them properly
- **The reasons** for the use of personal protective equipment and clothing
- Monitoring procedures used in their area of work, the **reasons they were put in place**, the **results of any monitoring** of their own personal exposure and generalised monitoring results for the area they work in
- The role of health surveillance, their duties to attend for such surveillance, **results of their personal health surveillance and generalised results of all health surveillance** in the area in which they work (presented in such a way to prevent identification of individuals).

All COSHH assessments must be readily available to staff working with the substances assessed. Staff should be required to sign an agreement to operate under safe system of work for the use of substances assessed under COSHH. It is important to **include as many staff as possible in the**

development of COSHH assessments and in their review. Such involvement makes it certain that staff understand what the risks are and why particular controls are in place; it also encourages ownership of the safe systems of work.

Training requirements are covered under “**competent persons**”.

All line managers with responsibilities for areas where chemicals, and other relevant substances, are used should have attended the “Safety management in a research environment” course which has a component on COSHH. A course is available on use of the COSHH software; all staff ordering and/or using chemicals must attend this course.

Emergency procedures and first aid. For all chemicals and other substances on site, you must know how you will clean up spills safely and what first aid is required if staff are exposed through the inhalation, dermal or ingestion routes. Such information is available on the electronic systems detailed in Appendix II. **This information must be kept separate from the laboratory or other work area where the substances are being used, or copies kept separately – in an emergency situation, you do not want to be searching for information close to where a spill has taken place.** General information on first aid for chemicals is presented in Appendix IV.

Disposal. For all chemicals and other substances on site, you must know how you can dispose of residues and spare material safely. This should be recorded along with the risk assessment of the substance. Information is available on the electronic systems detailed in Appendix II.

Authorisation. Authorisation to purchase chemicals must be made by a **competent person**; authorisation of COSHH risk assessments is by the appropriate line manager who should satisfy him/herself that adequate competence has gone into its preparation.

Record actions. Appropriate record keeping is addressed in the sections above.

Encourage and monitor feedback. Staff using chemicals and other substances should be encouraged to report to line managers anything which suggests to them that safe systems of work are not operating adequately. This might include:

- Symptoms of ill health or discomfort (for example headaches when using solvent) which suggest that containment is not working
- Spills of substances occurring regularly which might suggest inappropriate equipment or techniques
- Bad housekeeping by users of laboratories or other facilities which might lead to spills or other accidents
- Poor labelling of containers.

ROLES AND RESPONSIBILITIES

Director Centre/Survey: It is the Director's responsibility to ensure that the management structures required to satisfy the guidance in this Procedure are in place and that the safety management system is operating as intended. This requires inspection and audit at all levels against specific COSHH endpoints. Annual reporting of safety performance to NERC level.

Site Director/ Head of Administration: Assessment of chemicals, substances and products on site. Clear delegation to line managers of specific responsibilities. Determining which level of line management shall be responsible for record holding (normally the next lower level on site). Designating physical areas of the site as within the management responsibility of specific line managers. Monitoring the effectiveness of assessments, follow-up and the line management of health & safety. Cooperation with Research Centre-level auditing. Annual reporting to Research Centre Director of health & safety performance. Initiating and monitoring the maintenance of containment and ventilation equipment. Organisation of any monitoring of levels of substances in workplace air and health surveillance identified from COSHH assessments.

Division/ Section/ Group/ Unit heads: Generation of COSHH assessments, Safe Systems of Work (where appropriate) and their authorisation. Record keeping and monitoring effectiveness of safety systems. Inspection of laboratories and other areas using substances which fall under the Regulations within their physical area of management responsibility. Enforcement of safety instructions and encouragement of safety culture. Annual reporting to Site Director. **All levels of line management should be involved in health and safety management.**

Competent persons: Regulation 12(3) of COSHH requires that "Every employer shall ensure that any person (whether or not his employee) who carries out any work in connection with the employer's duties under these Regulations has the necessary information, instruction and training." In practice, this requirement needs to be interpreted alongside the definition of a "suitable and sufficient" risk assessment: "An assessment can be considered suitable and sufficient if the detail and expertise with which it is carried out are commensurate with the nature and degree of risk arising from the work, as well as the complexity and variability of the process."

Basic training in COSHH assessment is a requirement for anyone authorised to approve risk assessments of substances. This could be done by an outside trainer but managers must assure themselves that the training covers the methods of assessment outlined in this Procedure. Training done on-site is acceptable and may be desirable in many cases; this must be approved by management and a record kept of personnel trained. This basic training will not be adequate where particularly high hazard or risk is identified in the initial assessment or where the research requires use of substances outside the containment level recommended by the basic assessment. In these cases, further consultation must be made with those with specialist expertise. If in doubt, consult local, Research Centre or NERC Safety advisers.

Staff: All staff working with chemicals or other substances covered by COSHH must be aware of, and abide by, all instructions on risk mitigation. Staff must be aware of any emergency procedures required and of the recommended safe methods of disposal of the substances. The Regulations require the employer to make staff aware of **why** particular instructions/procedures are in place. **Staff must satisfy themselves that that they are aware of both instructions and the reasoning behind them and ask their line managers for clarification if they are not.**

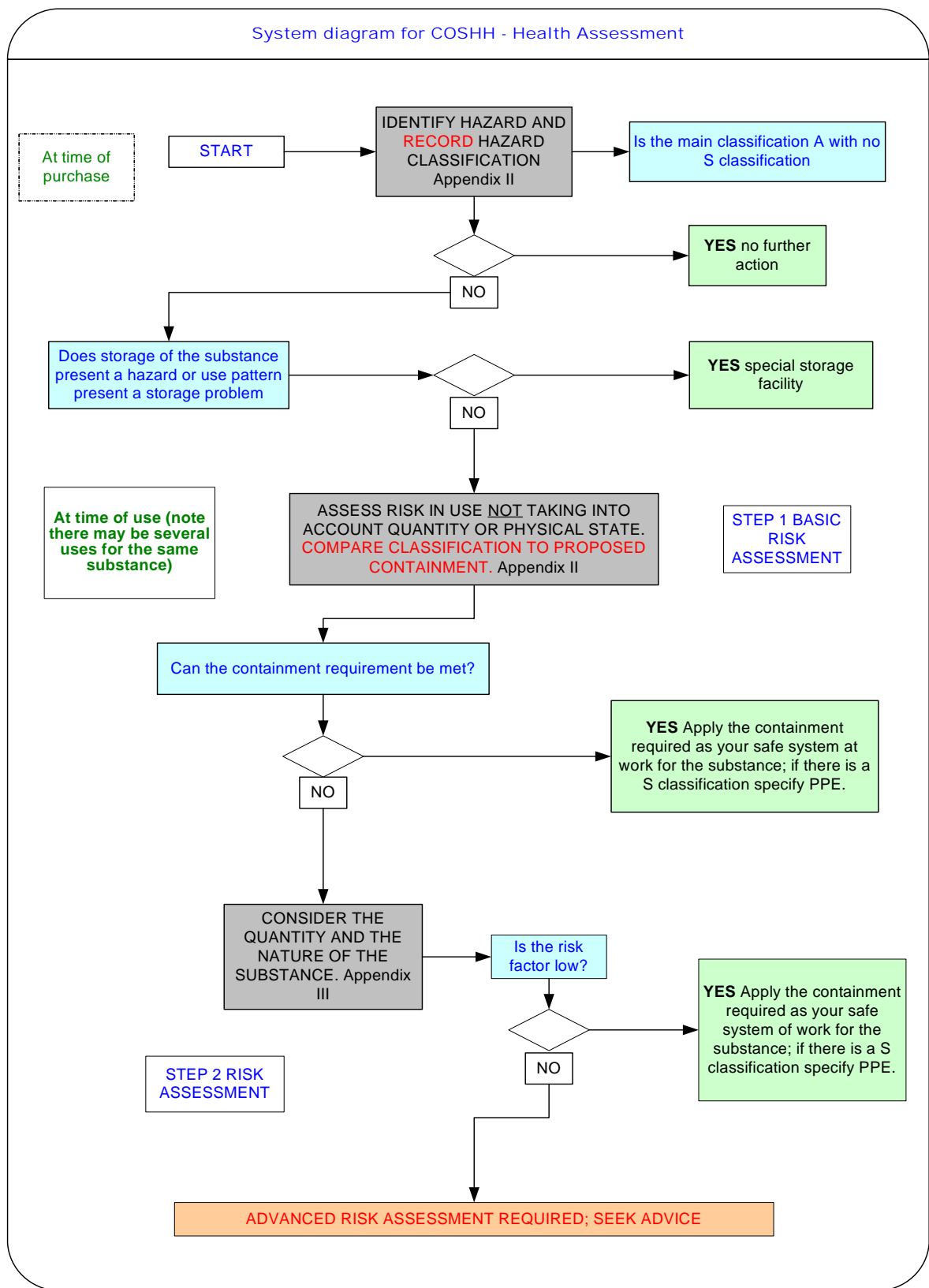

NOTE THAT ASSESSMENT OF EMERGENCY SPILLS PROCEDURES, FIRST AID AND SAFE DISPOSAL IS ALSO REQUIRED UNDER COSHH.

WHAT MIGHT GO WRONG? – probable sources of system and individual failure

Management:

Incomplete assessment of substances It is very easy given the large number of chemicals and other substances used on NERC sites for some to get forgotten. **Remedy** – Link the purchase of chemicals and other substances falling under COSHH to the provision of hazard and risk assessments. At least the basic assessment is then assured. Further uses of the substances for other purposes than intended by the initial purchase then need to be assessed; link high risk associated with one use to prioritising such substances being assessed in other uses.

Students and visitors It is very easy for substances to be brought onto NERC sites by students, visitors and collaborators without their being properly assessed. **Remedy** – Make sure that responsibilities under safety legislation are carefully defined when setting up studentships or collaboration. The requirement for this and means to manage it are set out in the **Management of Health & Safety Regulations 1999; regulations 11 and 12.**

MAKE SURE THE MESSAGE IS CONVINCING, CONSISTENT AND ENFORCED

Staff:

Familiarity with chemicals Very familiar chemicals or other substances can lead to complacency about hazards or risks. **Remedy** – Be aware of the real risks associated with chemicals you use all the time.

MANAGEMENT, MONITORING AND AUDITING

Management:

The management of COSHH requires:

- Assessment of the hazard and risk of all substances used on NERC sites
- Provision of engineering controls to allow containment to the level indicated by the risk assessment
- The maintenance and monitoring of engineering controls to meet containment guidelines issued by NERC
- The assessment of the need for monitoring of substance levels in workplace air and the recording of any monitoring performed
- The assessment of the need for health surveillance and its provision and management if necessary
- Provision of information to staff on what controls have been put into operation and why
- Training of staff and managers in COSHH assessment

Monitoring:

The monitoring of COSHH requires:

- Assurance that the control systems are being operated by staff
- Maintenance records of engineering controls
- An information system to ensure that the latest information on chemical hazard is available

Auditing:

The auditing of COSHH requires:

- Checking that staff understand the requirements of the risk control for substances
- Checking completeness of COSHH assessment
- Checking records on monitoring, health surveillance and maintenance of equipment

APPENDIX I: THE CONTROL OF SUBSTANCES HAZARDOUS TO HEALTH REGULATIONS (2002) - Summary

The primary function of the **Control of Substances Hazardous to Health Regulations (2002)** is to ensure that employers carry out an assessment to:

- Identify substances **hazardous** to health used in any aspects of the work
- **Demonstrate** readily to him/herself and to others that **all factors pertinent to the work** have been considered
- Demonstrate that a **valid judgement** has been reached about the **risk**
- Identify steps needed to **achieve** and **maintain** adequate control
- Decide on the need for workplace **monitoring** and/or **health surveillance**.

The requirement is for a “**suitable and sufficient**” assessment; this is defined as follows:

- *“An assessment can be considered suitable and sufficient if the detail and expertise with which it is carried out are commensurate with the nature and degree of risk arising from the work, as well as the complexity and variability of the process.”*

APPENDIX II: SOURCES OF INFORMATION ON THE HAZARDS OF CHEMICALS AND OTHER SUBSTANCES

There are a number of recognised sources of information on hazard of substances:

- Manufacturers are obliged to provide information (Safety Data Sheets). These can also be downloaded from the web. They are often not user friendly and it is difficult to pick out the crucial hazards. However, it should be standard practice to ask for these when substances are ordered from commercial suppliers. It is the only source of information for consumer products such as cleaning agents and paints. **Use with care. Suppliers of commercial products containing chemicals usually simply list all of the R phrases for each of the components. This can lead to ridiculous conclusions from a basic COSHH assessment. A small amount of solvent in a predominantly aqueous product often attracts a “flammable” R phrase, for example. Irritancy is expressed in terms of a concentrate of a minor component and, therefore, overestimates the risk etc.**
- Electronic systems with hazard information (e.g. International Programme on Chemical Safety (IPCS) at www.inchem.org). This is probably the best source of information since they give not only hazards but also occupational exposure limits and disposal, emergency clean-up and first aid information. This site can be accessed without the need for subscription.
- EU “risk phrases” are the basis of the HSE classification system for chemical hazard. They are available in chemical catalogues as well as in the above sources
- Hazard icons found on labels have limited value but are useful visual aids for labelling secondary containers.

APPENDIX III: EU RISK PHRASES AND HAZARD CLASSIFICATION

The following tabulates all EU Risk Phrases (note that “risk phrases” actually express hazard not risk). Each Phrase has been allocated a hazard classification. For those health-related Phrases allocated a classification by HSE, the classes are indicated as A to E. For those presenting a safety rather than health hazard (flammability, explosibility etc.) the hazard is classified as high, medium or low; this system is used to assess physical hazards and risks under the **Dangerous Substances and Explosive Atmospheres Regulations (2002)**. There is also an “environmental” classification which informs decisions on disposal routes. Special hazards (skin or eye effects, skin absorption, sensitization etc.) are indicated separately since these hazards may overlap with the main classification. The hazard code is a simple number which brings all classifications together.

R number	R phrase	Hazard classification	Special hazards	Hazard code
1	Explosive when dry	High		3
2	Risk of explosion by shock, friction, fire or other sources of ignition	High		3
3	Extreme risk of explosion	High		3
4	Forms very sensitive explosive metallic compounds	High		3
5	Heating may cause explosion	High		3
6	Explosible with or without contact with air	High		3
7	May cause fire	High		3
8	Contact with combustible materials may cause fire	High		3
9	Explosive when mixed with combustible materials	High		3
10	Flammable	Medium		2
11	Highly Flammable	Medium		2
12	Extremely Flammable	High		3
13	There is no R13 risk phrase			
14	Reacts violently with water	High		3
15	Contact with water liberates extremely flammable gases	High		3
16	Explosive when mixed with oxidising substances	High		3
17	Spontaneously flammable in air	High		3
18	In use may form flammable/explosive vapour air mixture	High		3
19	May form explosive peroxides	High		3
20	Harmful by inhalation	B		2
21	Harmful in contact with skin	B	Skin/eyes	2
22	Harmful if swallowed	Medium		2
23	Toxic by inhalation	C		2
24	Toxic in contact with skin	C	Skin/eyes	2
25	Toxic if swallowed	Medium		2
26	Very toxic by inhalation	D		3
27	Very toxic in contact with skin	D	Skin/eyes	3
28	Very toxic if swallowed	D		3
29	Contact with water liberates toxic gas	High		3
30	Can become highly flammable in use	High		3
31	Contact with acids liberates toxic gas	High		3
32	Contact with acids liberates very toxic gas	High		3
33	Danger of cumulative effects	Medium		2
34	Causes burns	C	Skin/eyes	2
35	Causes severe burns	C	Skin/eyes	2
36	Irritating to the eyes	A	Skin/eyes	1
37	Irritating to the respiratory system	C		2
38	Irritating to the skin	A	Skin/eyes	1
39	Danger of very serious irreversible effects	E		3
40	Limited evidence of carcinogenicity	E		3
41	Risk of serious damage to eyes	C	Skin/eyes	2

42	May cause sensitisation by inhalation	E	Sensitizer	3
43	May cause sensitisation by skin contact	C	Sensitizer	2
44	Risk of explosion if heated under confinement	High		3
45	May cause cancer	E		3
46	May cause heritable genetic damage	E	Reprotox	3
47	There is no R47 risk phrase			
48	Danger of serious damage to health by prolonged exposure	D		3
49	May cause cancer by inhalation	E		3
50	Very toxic to aquatic organisms	Environ		1
51	Toxic to aquatic organisms	Environ		1
52	Harmful to aquatic organisms	Environ		1
53	May cause long-term adverse effects in the aquatic environment	Environ		1
54	Toxic to flora	Environ		1
55	Toxic to fauna	Environ		1
56	Toxic to soil organisms	Environ		1
57	Toxic to bees	Environ		1
58	May cause long-term adverse effects in the environment	Environ		1
59	Dangerous to the ozone layer	Environ		1
60	May impair fertility	D	Reprotox	3
61	May cause harm to the unborn child	D	Reprotox	3
62	Possible risk of impaired fertility	D	Reprotox	3
63	Possible risk to the unborn child	D	Reprotox	3
64	May cause harm to breast fed babies	D	Reprotox	3
65	Harmful: May cause lung damage if swallowed	Medium		2
66	Repeated exposure may cause skin dryness or cracking	Low		1
67	Vapours may cause drowsiness and dizziness	Low		1
68	Possible risk of irreversible effects	E		3
14/15	Reacts violently with water, liberating extremely flammable gases	High		3
15/29	Contact with water liberates toxic, extremely flammable gas	High		3
20/21	Harmful by inhalation and in contact with skin	B	Skin/eyes	2
20/21/22	Harmful by inhalation, in contact with skin and if swallowed	B	Skin/eyes	2
20/22	Harmful by inhalation and if swallowed	B		2
21/22	Harmful in contact with skin and if swallowed	B	Skin/eyes	2
23/24	Toxic by inhalation and in contact with skin	C	Skin/eyes	2
23/24/25	Toxic by inhalation, in contact with skin and if swallowed	C	Skin/eyes	2
23/25	Toxic by inhalation and if swallowed	C		2
24/25	Toxic in contact with skin and if swallowed	C	Skin/eyes	2
26/27	Very toxic by inhalation and in contact with skin	D	Skin/eyes	3
26/27/28	Very toxic by inhalation, in contact with skin and if swallowed	D	Skin/eyes	3
26/28	Very toxic by inhalation and if swallowed	D		3
27/28	Very toxic in contact with skin and if swallowed	D	Skin/eyes	3
36/37	Irritating to eyes and respiratory system	C	Skin/eyes	2
36/37/38	Irritating to eyes, respiratory system and skin	C	Skin/eyes	2
36/38	Irritating to eyes and skin	A	Skin/eyes	1
37/38	Irritating to respiratory system and skin	C	Skin/eyes	2
39/23	Toxic: danger of very serious irreversible effects through inhalation	D		3
39/23/24	Toxic: danger of very serious irreversible effects through inhalation and in contact with skin	D	Skin/eyes	3
39/23/24/25	Toxic: danger of very serious irreversible effects through inhalation, in contact with skin and if swallowed	D	Skin/eyes	3

39/23/25	Toxic: danger of very serious irreversible effects through inhalation and if swallowed	D		3
39/24	Toxic: danger of very serious irreversible effects in contact with skin	D	Skin/eyes	3
39/24/25	Toxic: danger of very serious irreversible effects in contact with skin and if swallowed	D	Skin/eyes	3
39/25	Toxic: danger of very serious irreversible effects if swallowed	C		2
39/26	Very Toxic: danger of very serious irreversible effects through inhalation	E		3
39/26/27	Very Toxic: danger of very serious irreversible effects through inhalation and in contact with skin	E	Skin/eyes	3
39/26/27/28	Very Toxic: danger of very serious irreversible effects through inhalation, in contact with skin and if swallowed	E	Skin/eyes	3
39/26/28	Very Toxic: danger of very serious irreversible effects through inhalation and if swallowed	E		3
39/27	Very Toxic: danger of very serious irreversible effects in contact with skin	E	Skin/eyes	3
39/27/28	Very Toxic: danger of very serious irreversible effects in contact with skin and if swallowed	E	Skin/eyes	3
39/28	Very Toxic: danger of very serious irreversible effects if swallowed	D		3
42/43	May cause sensitisation by inhalation or skin contact	E	Sensitizer	3
48/20	Harmful: danger of serious damage to health by prolonged exposure through inhalation	C		2
48/20/21	Harmful: danger of serious damage to health by prolonged exposure through inhalation and in contact with skin	C	Skin/eyes	2
48/20/21/22	Harmful: danger of serious damage to health by prolonged exposure through inhalation and if swallowed	C	Skin/eyes	2
48/20/22	Harmful: danger of serious damage to health by prolonged exposure through inhalation, in contact with skin and if swallowed	C	Skin/eyes	2
48/21	Harmful: danger of serious damage to health by prolonged exposure in contact with skin	C	Skin/eyes	2
48/21/22	Harmful: danger of serious damage to health by prolonged exposure through inhalation and if swallowed	C	Skin/eyes	2
48/22	Harmful: danger of serious damage to health by prolonged exposure if swallowed	C		2
48/23	Toxic: danger of serious damage to health by prolonged exposure through inhalation	D		3
48/23/24	Toxic: danger of serious damage to health by prolonged exposure through inhalation and in contact with skin	D	Skin/eyes	3
48/23/24/25	Toxic: danger of serious damage to health by prolonged exposure through inhalation and if swallowed	D		3
48/23/25	Toxic: danger of serious damage to health by prolonged exposure through inhalation, in contact with skin and if swallowed	D	Skin/eyes	3
48/24	Toxic: danger of serious damage to health by prolonged exposure in contact with skin	D	Skin/eyes	3
48/24/25	Toxic: danger of serious damage to health by prolonged exposure through inhalation and if swallowed	D		3
48/25	Toxic: danger of serious damage to health by prolonged exposure if swallowed	D		3
50/53	Very toxic to aquatic organisms, may cause long-term irreversible effects in the aquatic environment	Environ		1

51/53	Toxic to aquatic organisms, may cause long-term irreversible effects in the aquatic environment	Environ		1
52/53	Harmful to aquatic organisms, may cause long-term irreversible effects in the aquatic environment	Environ		1
68/20	Harmful: possible risk of irreversible effects through inhalation	E/D		3
68/20/21	Harmful: possible risk of irreversible effects through inhalation and in contact with skin	E/D	Skin/eyes	3
68/20/21/22	Harmful: possible risk of irreversible effects through inhalation, in contact with skin and if swallowed	E/D	Skin/eyes	3
68/20/22	Harmful: possible risk of irreversible effects through inhalation and if swallowed	E/D		3
68/21	Harmful: possible risk of irreversible effects in contact with skin	E/D	Skin/eyes	3
68/21/22	Harmful: possible risk of irreversible effects in contact with skin and if swallowed	E/D	Skin/eyes	3
68/22	Harmful: possible risk of irreversible effects if swallowed	E/D		3

Note: The definition of R40 was changed in 2005; the old definition of R40 was assigned to R68. Old combination phrases involving R40 now have R68 instead.

APPENDIX IV: ESTIMATION OF EXPOSURE TO REFINE THE BASIC COSHH ASSESSMENT

For risk assessment of chemicals under COSHH, the Royal Society of Chemistry has produced the following methodology which takes account of the quantity, physical characteristics of the chemical along with the containment method to be used. This forms the second step in the NERC Procedure. Scores are derived which give an indication of likely exposure to chemicals via the inhalation and dermal routes separately as follows:

A. Contribution from inhalation (vapour pressure: mmHg = kPa/0.1333)

Score	1	10	100
Quantity of substance	< 1 g	1 to 100g	> 100g
Physical characteristics of substance as used	Dense solids, non-volatile liquids Vapour pressure up to 0.1 mmHg	Dusty solids, lyophilised solids, volatile liquids Vapour pressure 0.1 to 10 mmHg	Gases, very volatile liquids, aerosols Vapour pressure >10 mmHg
Containment	Enclosed system/ fume cupboard	Local ventilation/filtered hood	Open bench

B. Contribution from skin contact (vapour pressure: mmHg = kPa/0.1333)

Score	1	10	100
Quantity of substance	< 1 g	1 to 100g	> 100g
Physical characteristics of substance as used	Gases, highly volatile liquids, massive solids	Liquids of medium volatility, hygroscopic or deliquescent solids, dusty solids, aerosols	Liquids of low volatility
Containment	Enclosed system/ fume cupboard	Local ventilation/filtered hood	Open bench

For each of the routes of exposure, scores for quantity, physical characteristics and containment are multiplied together to derive an overall exposure score. Scores are classified as:





Scores 1, 10 or 100	Indicative of low exposure
Scores 1000 or 10000	Indicative of medium exposure
Scores 100000 or 1000000	Indicative of high exposure

Note that for small quantities of substances (<1g) used entirely in a fume cupboard, even those with characteristics most likely to lead to exposure, the exposure score is LOW. Keeping quantities of chemicals used or kept in laboratories to the minimum and using all hazardous materials fully inside a fume cupboard which meets the containment criteria in Appendix VI will generally ensure their safe use.



APPENDIX V: GENERAL GUIDANCE ON FIRST AID FOLLOWING EXPOSURE TO CHEMICALS

Chemical exposure

click icon for hazard of chemical

				
TOXIC	HARMFUL /IRRITANT	OXIDISING	FLAMMABLE	CORROSIVE

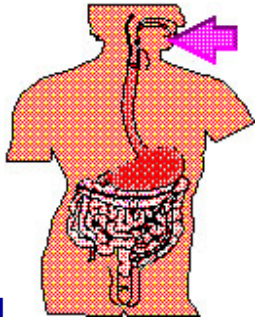
	<p>TOXIC & VERY TOXIC CHEMICALS</p> <p style="background-color: yellow;">Always call a qualified First Aider</p>
---	---

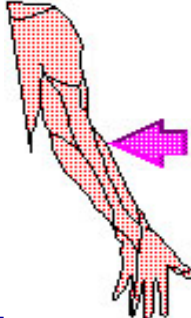
 <p>INGESTION</p>	 <p>INHALATION</p>	 <p>DERMAL</p>
<p>Wash out mouth with water. DO NOT induce vomiting . Give sips of water. Use specific antidote if available. Call emergency services immediately. Have container or safety data sheet ready for their arrival. Check for specific advice on safety data sheet. Consult Safety Advisers for advice.</p>	<p>Normally would be exposure to vapour, gas or aerosol. DO NOT PUT YOURSELF IN DANGER. Remove patient to well ventilated area or the open air. Put in recovery position and ensure airway is open by tipping back head. DO NOT perform mouth-to-mouth resuscitation. Call emergency services. Consult Safety Advisers for advice.</p>	<p>Wash with copious quantities of water. DO NOT abrade the skin, DO NOT apply solvents or creams. Call emergency services unless you are SURE that the toxin is NOT dermally absorbed. Have container or safety data sheet ready for their arrival. Consult Safety Advisers for advice.</p>



FLAMMABLE CHEMICALS - Normally solvents
Always call a qualified First Aider

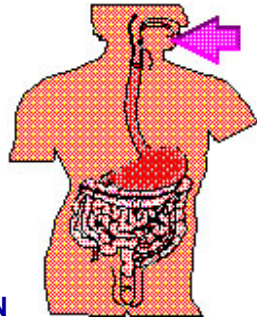

INGESTION

Call emergency services immediately. Have container or safety data sheet ready for their arrival. Consult Safety Advisers for advice.



INHALATION

Normally would be exposure to vapour. Remove patient to well ventilated area or the open air. DO NOT perform mouth-to-mouth resuscitation. Call emergency services. Consult Safety Advisers.

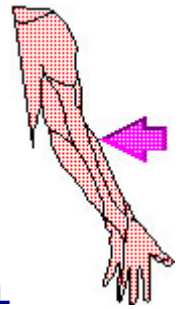

DERMAL

Wash with copious quantities of water. DO NOT abrade the skin. Longer-term, watch for irritant dermatitis. Consult Safety Advisers for advice. If solvent is dermally absorbed and/or toxic, consult medical services.



HARMFUL OR IRRITANT CHEMICALS

Always call a qualified First Aider

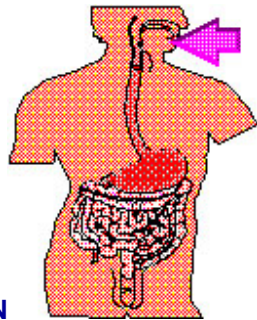

INGESTION

Wash mouth thoroughly and repeatedly with water. Give sips of water. Call emergency services immediately. Milk may reduce irritation if substance is in the stomach. Have container or safety data sheet ready for their arrival. Consult Safety Advisers for advice.

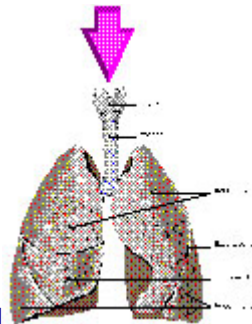

INHALATION

Normally would be exposure to vapour or aerosol. Remove patient to well ventilated area or the open air. Call emergency services. Consult Safety Advisers.



DERMAL

Wash with copious quantities of water. **DO NOT** abrade the skin. Longer-term, watch for irritant dermatitis. Consult Safety Advisers for advice. If the chemical is dermally absorbed, call emergency services. Otherwise, consult medical services.



OXIDIZING OR CORROSIVE CHEMICALS

Always call a qualified First Aider

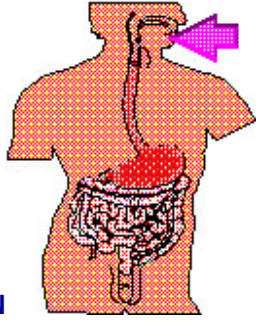

INGESTION

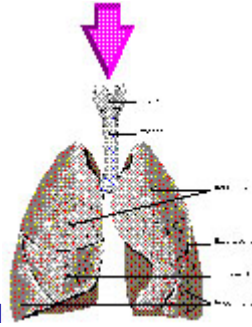

INHALATION

DERMAL

Wash mouth thoroughly and repeatedly with water. Milk may reduce irritation if substance is in the stomach. Call emergency services immediately. Have container or safety data sheet ready for their arrival. Consult Safety Advisers for advice.

Normally would be exposure to aerosol or vapour. Remove patient to well ventilated area or the open air. DO NOT give mouth-to-mouth resuscitation. Call emergency services immediately. Consult Safety Advisers.

Wash with copious quantities of water. DO NOT use soap or creams. DO NOT abrade the skin. Patient should be taken quickly to local hospital.

The safe use, maintenance, and testing of laboratory fume cupboards

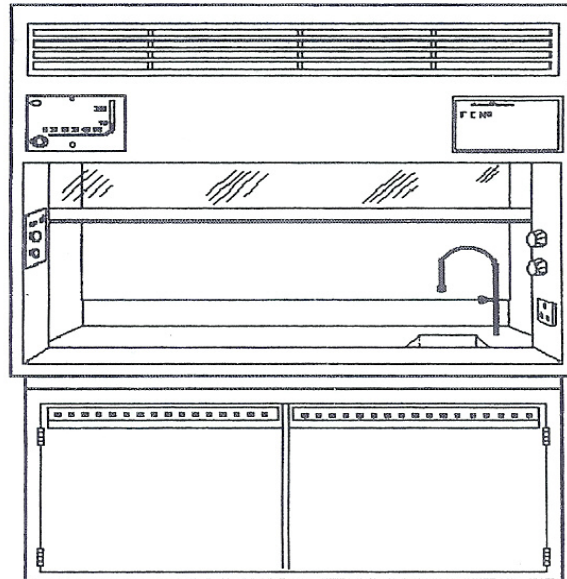

December 2007

**THIS DOCUMENT REPLACES THE NERC GUIDANCE NOTE – THE SAFE USE,
MAINTENANCE AND TESTING OF LABORATORY FUME CUPBOARDS, ISSUED IN 1994
AND UPDATED IN 2003 and 2005**

This version refers to the new EN 14175 which replaces BS 7258 and further refers to NERC containment values which are more stringent than those in the EN.

It is intended to support the NERC Procedure No19, COSHH and provides guidance on legislation applicable to fume cupboards, specifications for fume cupboards and their safe use.

Guidance is provided for:

- (a) planned preventative maintenance to meet the Statutory requirement for thorough inspection under the COSHH Regulations and
- (b) the proof of satisfactory containment as required by NERC
 - (1) on fume cupboard enclosures following installation by the contractor. Testing is the responsibility of the contractor and is NOT covered by the manufacturers "type test"
 - (2) following major repairs or alterations to the fume cupboard or room
 - (3) prior to the start of a high hazard process

COSHH assessments in NERC are based on containment as recommended by HSE and the Royal Society of Chemists.

It should be noted that the standards set by NERC on the authority of the NERC Safety Management Team are quantitative and therefore more stringent than the recommendations in EN 14175

Satisfactory containment is established by the introduction of sulphur hexafluoride (SF₆) and monitoring the level of escape from the sash aperture. There will be situations where use of sulphur hexafluoride is not possible (analytical work on fluorides, clean laboratories where the equipment cannot be brought into the room etc.). Here we need a stepwise approach:

- Look at the substances being used in the particular fume cupboard and put them through the COSHH software
- If all of the substances require levels of containment below Class 2, no further action is needed since even a poorly performing cupboard will provide the general ventilation required for inhalation hazard Class B substances

If some substances require containment at Class 2 (inhalation hazard Class C substances), monitoring concentrations in laboratory air replaces fume cupboard containment testing. Such monitoring should be regular and documented. If the substances have WELs (Workplace Exposure level) values (from HSE's EH40 publication), these must not be exceeded

- If some substances require containment at Class 1 (inhalation hazard Class D/E substances), monitoring in laboratory air should be accompanied by personnel monitoring to ensure that staff are not inhaling or otherwise absorbing the substance. Class 1 containment is normally required for substances which are carcinogens, sensitisers, genotoxins or cause long-term irreversible damage to health. We are obliged to ensure that exposure is kept to the minimum technically achievable. Records of personal exposure must be kept for 40 years. Seek advice for methods to biologically monitor personnel exposure which will be substance-specific. If the substances have WELs (Workplace Exposure level) values (from HSE's EH40 publication), these must not be exceeded

List of contents

Part 1. Introduction.

2. Legislation.

- 2:1. Health and Safety at Work etc Act 1974.
- 2:2. Control of Substances Hazardous to Health Regulations 2002.
- 2:3. Management of Health and Safety at Work Regulations 1999.
- 2:4. Provision and Use of Work equipment Regulations 1998.
- 2:5. Electricity at Work Regulations 1989.
- 2:6. Environmental legislation.

3. Minimum specification for fume cupboard systems.

- 3:1. System identification.
- 3:2. System performance.
- 3:3. Fume cupboard enclosure.
- 3:4. Sash.
- 3:5. Spill containment.
- 3:6. Services.
- 3:7. Air flow indicator.
- 3:8. Ductwork.
- 3:9. Fan.
- 3:10. Fume discharge point.
- 3:11. Positioning of fume cupboards.
- 3:12. Make-up air.

4. Safe use of fume cupboard systems.

- 4:1. Risk assessment.
- 4:2. Fume cupboard selection.
- 4:3. Construction and configuration of experiment.
- 4:4. Cupboard contents.
- 4:5. Storage of materials in fume cupboards.
- 4:6. Pre-use operator checks.

5. Maintenance schedules.

- 5:1. Frequency of maintenance.
- 5:2. Hazards during maintenance work.
- 5:3. Record keeping.
- 5:4. Post maintenance performance testing.

6. Performance testing.

- 6:1. Frequency of testing.
- 6:2. Record keeping.
- 6:3. Test principles.
- 6:4. Instrumentation.
- 6:5. Fume cupboard test procedures:
 - 1). Containment.
 - 2). Face velocity.
 - 3). Flow visualisation.
 - 4). Engineering measurements.

- Appendixes:**
- A. Recirculating and portable fume cupboards.
 - B. Auxiliary air fume cupboards.
 - C. Wet-scrubbed systems.
 - D. Example documents.

Part 1. Introduction

Fume cupboard systems are the most common control measure employed within NERC laboratories for the prevention of exposure to hazardous substances. The legislation governing their use, and the understanding of how they arrest and contain contaminants have developed significantly over the last few years. It is intended that this Code of Practice will establish a common operating policy throughout NERC in response to these developments.

The Code is intended for use by anyone with an interest in fume cupboard operations including users, maintenance engineers and health and safety practitioners. The document should be seen as a first reference source, but directs the reader to definitive source documents where this might be useful. To enable easier identification of key recommendations a series of section and sub-section numbering has been employed.

The Code is concerned mainly with permanently installed systems, although appendix A does provide some guidance on recirculating portable devices. It does not consider microbiological safety cabinets, or other forms of local exhaust ventilation (LEV).

Part 2. Legislation

The following is a brief summary of the main legislation relevant to the use of laboratory fume cupboards in research environments. For further information the statutory instrument's, supporting Approved Codes of Practice (ACOPs), and relevant NERC guidance notes should be referenced.

2:1. Health and Safety at Work etc Act 1974

The principle legislation regulating work activity by means of the establishment of various *general duties* on employers to ensure, *so far as is reasonably practicable*, the health, safety and welfare of employee's at work. This generality is expanded by the following subsections:

- a) the provision and maintenance of *plant and systems of work* that are safe and without risks to health.
- b) arrangements for ensuring the absence of risks to health in connection with the use, handling, storage and transport of articles and substances.
- c) the provision of information, instruction, training and supervision necessary to ensure the health and safety of employees.
- d)

Duties are established for employees to take reasonable care of their own health and safety, and that of others, and to co-operate with their employees with regard to measures devised to ensure health and safety (ie. implement this code). In addition there is a section requiring employers to prevent harmful emissions into the atmosphere.

2:2. Control of Substances Hazardous to Health (COSHH) Regulations 2002 These regulations are the most significant in terms of the use of hazardous substances, and in the control measures used to prevent exposure to them. The primary requirement is to prevent exposure of employees (or others likely to be effected), but where this is not possible to make an assessment of the likely exposure, and to thereafter control it to within acceptable level's (workplace exposure levels). Where necessary control can be achieved by measures such as *local exhaust ventilation (LEV)*, the classification of mechanical ventilation devices in which laboratory fume cupboards are placed.

The regulations establish the requirement for LEV systems to be maintained in suitable condition, and subject to thorough examination and testing at periods not greater than fourteen months, and more frequently if the assessment identifies higher risk (Reg 9). This regulation is supported in some detail by notes in the approved code of practice, which have been used as the basis for the maintenance section of this code. There is a specific requirement for users of fume cupboards to make *daily checks* of certain functions of the system, and to report any faults to management as soon as is reasonably possible.

2:3. Management of Health and Safety at Work (MHSW) Regulations 1999

The regulations require that a *suitable and sufficient risk assessment* be made prior to a work activity being undertaken, and that the subsequent arrangements, along with the capabilities and training of those required to do the work, are based upon this assessment. In terms of fume cupboard work this is most relevant when considering the design of experiments within existing cupboards, and is fully considered in part 4 of this code (*Safe use of fume cupboard systems - 4:1. Risk assessment*).

2:4. Provision and Use of Work Equipment (PUWE) Regulations 1998

These regulations are comprehensive in their requirements for *work equipment*, in which fume cupboard systems are included. In general terms equipment has to be constructed and adapted so as to be suitable for its intended purpose (Reg 5), maintained in efficient working order and in good repair (Reg 6). Maintenance operations are given further consideration (Reg 22) in order that sufficient protection is afforded to maintenance workers, and to the prevention of the unintended discharge of any article, gas or vapour (Reg 12). The unambiguous marking of controls, warning devices, and fault condition monitors (ie flow indicators) is required and, in common with other legislation, the provision of adequate information, instruction, and training is specified.

2:5. Electricity at Work Regulations 1989

This is relevant for the design and continued maintenance of the electrical systems associated with fume cupboards. Particular attention should be paid to Reg 5 which establishes the need for the mechanical integrity of electrical equipment, this being relevant to corrosion sometimes experienced by electrical systems exposed to environmental conditions. In addition the *competence* to undertake maintenance work (Regs 3 & 16), the need for *isolation of energy sources*, and the use *effective control measures* (ie permits-to-work) (Regs 12 & 13) are necessary precautions.

2:6. Environmental legislation.

This code does not detail measures necessary to meet environmental legislation such as the *Environmental Protection Act (EPA)*, or the *Control of Pollution Act*, as it is unlikely that laboratory scale operations produce sufficient fume discharge to merit inclusion in these regulations. It is however important to note that the following activities may require co-ordination with local enforcing authorities:

- a) volume, concentration and composition of *liquid waste discharge* through the general drain system (this being subject to a *consent* negotiated with the relevant water authority);
- b) correct disposal of any special *waste materials* or *contaminated apparatus* through authorised disposal sites in accordance with EPA.

Part 3. Minimum specification for fume cupboard systems.

The following is a specification for the minimum requirements of a fume cupboard system for use within NERC laboratories. Failure to meet this specification should result in either:

- a) the complete withdrawal of the system from operation until modifications have been implemented to eliminate deficiencies or
- b) the limitation of use to low-risk work which has been subject to a risk assessment, and can be undertaken safely within the system allowing for its deficiencies.

In order to achieve the standards set by NERC (which apply to fume cupboards in their installed position), tenders should advise potential contractors of these requirements at the earliest opportunity and should also make clear the requirements for the provision of a suitable make-up air system.

3: 1. System identification.

All fume cupboard systems should be allocated a distinct identification number (eg. BGS-FC 1, CEH-FC 2), which should not be shared by any other system operating on that site. The number should be clearly marked on all parts of the system, including ductwork and fans where these might be confused with components of any other system.

3:2. System performance.

The primary function of a fume cupboard system is to contain and convey potentially dangerous or obnoxious fumes from the fume cupboard enclosure to an outside discharge point where it can be safely dispersed at low concentration. The operational system performance will be demonstrated in terms of a *containment test* and *face velocity measurements*. Details of performance evaluation tests are given in part 6 of this code.

3:3. Fume cupboard enclosure.

The enclosure shall be constructed of materials capable of resisting chemical or thermal attack from any substance or equipment used within it, including during escapes other than during normal operations. See

3:4. Sash.

The enclosure shall have a movable sash which will normally be lowered during operation, but which can easily be positioned at a higher level to allow periodic access to equipment within.

3:4:1. The sash must be sufficiently transparent to encourage the user to work behind it. If the glass is etched by acid, or marked by any form of obstruction it should be deemed unsuitable, and replacement arranged. It may be necessary to protect it from acid frosting by means of additional resistant film on the internal surfaces. In experiments where catastrophic failure can be explosive the sash should be of laminated glass or other suitable impact resistant material. Note *Wired Georgian Glass* is known to release fragments on explosive impact, and is not deemed suitable for such conditions.

3:4:2. The sash mechanism must incorporate a device to limit its movement such that a maximum aperture height of 0.5 m is maintained between the base of the cupboard and the underside of the sash. This is to be considered as the *maximum working aperture*, and should not be exceeded during normal operations. When it is necessary to exceed the maximum working aperture height, for instance whilst loading equipment during the setting up experiments, it should only be possible to do so after deliberately activating a *stop-release mechanism*.

3:5. Spill containment.

Where an experiment presents the possibility of accidental spillage of hazardous liquid within the enclosure, it will be necessary to incorporate features to contain the spill within the enclosure. The capacity of this feature must be capable of accepting the volume of the largest container housed within the fume cupboard.

3:6. Services.

With the exception of electrical supplies, the *outlets* to services shall be located on the *inner* surface of the enclosure. The *controls* shall be located on the *external* surfaces of the enclosure such that each control can be unambiguously associated with its outlet, and visibly marked in accordance with relevant standards.

3:6:1. Electrical outlets shall be located on the external surfaces of the enclosure, in such a position that it shall not be possible for liquids or flammable vapours flowing over the cupboards front edge (from spillages within) to come into contact with the electrical outlets.

3:7. Air flow indicator.

All fume cupboards should incorporate a means of unambiguously indicating to the operator that air is being extracted at a satisfactory rate. Where audible alarms are fitted with a mute facility, it is not permitted to carry out normal operation in the mute mode.

3:8. Ductwork.

Ductwork should be constructed of a material suitable for use with the materials intended for use within the fume cupboard. See EN 14175 for comprehensive guidance on material selection.

3:8:1. It is strongly recommended that each fume cupboard shall have a dedicated duct system and fan set. Where these are shared between more than one enclosure, facilities must exist to indicate failure of any part of the system and communicate that failure to ALL other parts of the system likely to be effected.

3:8:2. Where systems are used which allow the fumes from more than one enclosure to mix, a comprehensive risk assessment must be made, and control measures introduced to prevent the simultaneous use of incompatible substances.

3:8:3. Internal surfaces of ductwork should be smooth and free from obstruction.

3:8:4. The configuration of ducting should be designed to avoid features likely to allow the collection or concentration of contaminant; for example any long horizontal duct runs should be slightly inclined, and incorporate suitable drainage points.

3:8:5 All ducting should incorporate leak-proof inspection covers to allow easy internal inspections during periodic maintenance and examination.

3:8:6. All ducting between the fume cupboard enclosure and the fan which passes through any occupied space (ie offices or manned plantrooms) should be at negative pressure to the ambient room pressure to prevent the leakage of contaminant into the room during plant failure.

3:8:7. No ductwork should violate the fire compartmentation of the building in passing between the fume

cupboard and its final discharge point. Duct runs should be external to the building wherever possible. If this is not possible fire dampers will be required between compartments, and should be of suitable corrosion resistant design, be readily accessible for inspection and maintenance, and be regularly tested.

3:8:8. Where mechanically operated volume control dampers are located in a duct, they must incorporate a feature to deter the unauthorised operation. A lock-nut and an appropriate warning sign should be sufficient.

All parts of the fan likely to come into contact with the fume or its condensate should be resistant to them, and be able to withstand the maximum working temperature.

3.9. Fan

3:9:1. The fan motor should be situated outside the air stream to prevent the transmission of sparks to any potentially explosive fume within.

3:9:2. Designs incorporating *indirect drive* using pulley belts are recommended as they are known to allow flexible operation over a range of speeds (therefore air flow rates).

3:9:3 All components of the fan must allow access for inspection and maintenance, particularly the internal drum of the fan and its casing.

3:9:4. Belt drives must be *adequately guarded* to prevent accidental entanglement.

3:9:5. Fan sets and associated plant mounted externally at roof level should incorporate *barriers* and other safety features to prevent falls during maintenance activities..

3:9:6. Fan assemblies should incorporate *vibration damping gaiters* between isolating ducting and discharge stack. This will reduce noise transmission and reduce the potential for fatigue failure throughout the duct system.

3:10. Fume discharge point.

The complex conditions influencing the effectiveness of a fume discharge point are described in various literature and include building geometry, local meteorological and topographic conditions, and a host of other variables. In the absence of numerical modelling or wind-tunnel analysis the following basic guidance should be sufficient to maximise safety at discharge positions.

3:10:1. All exhaust stacks shall be of vertical circular section discharging at a height no less than 3m from roof level. The stack should incorporate a conical accelerator to increase discharge velocity and assist in fume dispersal.

3:10:2. The airflow velocity at the discharge point shall not be less than 10m/sec.

3:10:3. The fume should discharge above roof level (see 3:10:1), with care to avoid re-capture of any expelled contaminant by either natural ventilation features (windows) or other plant air -intakes.

3:10:4. When considering the discharge characteristics it is worth considering the worst likely environmental considerations, (ie a calm wind-less day). Flow visualisation using smoke generating devices may be a valid test for such conditions.

3:10:5. Certain limitations can be enforced by Local Authority Planning Departments in accordance with Town and Country Planning Regulations, typically restricting stack height. Where this compromises the safe operation of a system it will be appropriate to seek further advice from the LA.

3:10:6. Where fume cupboard discharge points on roofs are likely to expose maintenance workers (or others staff) requiring access to adjacent areas, it will be necessary to operate systems of work which will prevent exposure to hazardous concentrations of effluent. A permits-to-work system may be valid control measure.

3:11. Position of cupboard.

The position of a fume cupboard within a room will influence its ability to contain contaminants, so care must be taken to avoid close proximity to features known to cause adverse effect. These include: a) walls, columns, cabinets, work benches, or other features likely to disturb the flow of air through the enclosure: and b) traffic routes through the laboratory likely to result in disturbance. These problems are reduced by ensuring there is an *undisturbed zone* within which the operator can work at the enclosure face.

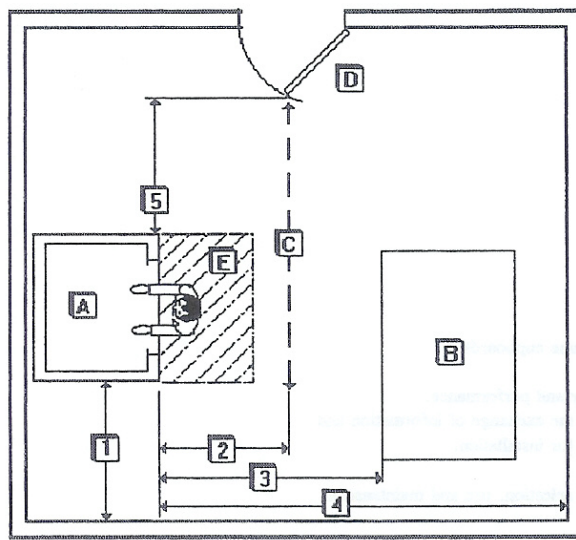

Figure 1.

	Feature of critical dimension.	Distance (mm)
A	Fume cupboard enclosure.	N/A
B	Bench positioned behind enclosure.	"
C	Traffic route.	"
D	Door.	"
E	Undisturbed operator zone - Width of enclosure x 1000mm approx.	"
1	Distance from side of enclosure to nearest wall or significant body (ie cabinets, column etc) Note. This does not include a second fume cupboard enclosure.	300
2	Distance from face of enclosure to traffic route.	1300
3	Minimum distance between face of enclosure and work bench.	1500
4	Minimum distance from face of enclosure to rear wall or major feature.	2000
5	Spacing between undisturbed zone and any regularly opening door. Fire escapes not in normal use are excluded from this requirement.	1000
See BS 7258 :Part 2: 1980 Section three for further details.		

3:12. Make-up air.

Fume cupboard systems should be provided with facilities to replace the air extracted from the room by the fume cupboard. This can be achieved by either positioning grilles in walls or doors to allow induction of treated air from adjacent offices or corridors although this method is not preferred due to potential disruption of airflow from adjacent events. Ideally, untreated air should be drawn from outside, and conditioned by a dedicated air handling unit. Care must be taken when utilising such powered make-up air, as the influence of high velocity currents within the proximity of the fume cupboard aperture can have an adverse effect on the containment performance of the cupboard. The make up air should be introduced at low velocity and as far as possible in line with, but not adjacent to the face of the enclosure.

Part 4. Safe use of fume cupboards.

A fume cupboard is a *partial containment device* and therefore, if the contaminant is so hazardous that *any leakage* into the working environment would be considered catastrophic, an alternative control measure will be necessary, for example a glove-box or microbiological safety cabinet.

The success or otherwise of the control afforded by a system will be dependant upon its suitability for the

intended circumstances and must be determined by a series of pre-activity planning measures, the most significant being the *risk assessment*.

4:1. Risk assessment.

Prior to any new experiment being undertaken within a fume cupboard it will be necessary to complete a risk assessment exercise. This may be considered as part of a COSHH assessment, but will include elements additional to chemical safety. The risk assessment will *identify the hazards* (ie substances or conditions with the potential to cause harm), and *evaluate the associated risks* (ie the likelihood of that harm being realised). The assessment must consider conditions other than the normal operating ones, ie spillage, catastrophic failure of any component within the system (ie fan), or any other condition likely to present adverse conditions. The assessment must consider the competence of those undertaking the work, and will determine the necessary levels of supervision. In all but low risk situations, where the reasoning of the assessment can be readily demonstrated, it will be necessary to produce a written record of the assessment.

Where a number of risks are anticipated it is useful to employ a *rating system* to allow comparison between risks, and enable appropriate priorities to be allocated. Site Local Safety Advisers should be approached for additional information on numerical risk assessments techniques.

4:2. Fume cupboard selection.

The hazards presented by an experiment must be matched to the capabilities of the system, therefore it is essential that performance data (ie containment test results) are considered as part of the risk assessment. In laboratories containing a number of fume cupboards it is likely that some will perform better than others. In such circumstances efforts must be made to use the most effective cupboards with the most hazardous experiments.

The physical integrity of the system must be considered, ie its ability to withstand corrosive acid fumes or its fire resistance when using highly flammable substances. EN 14175 should be reference for comprehensive construction material data. It is important to consider all parts of the system (ie ducting, fan-casing etc), and not just the enclosure.

4:2:1. No work should be carried out in a cupboard which has not been subject to a thorough examination and performance test within the last twelve months. A label should be displayed on each cupboard indicating when the last test was carried out.

4:3. Construction and configuration of experiment.

The configuration of the apparatus within the cupboard will have a critical influence on the airflow through the enclosure, and therefore its ability to contain the contaminant. The following points should be noted;

4:3:1. A *150mm wide equipment-free-zone* should be maintained behind the sash at all times. Experimental evidence has shown that if contaminants are released in this area there is a higher possibility of them being drawn out of the cupboard by convection currents caused by operator movements.

4:3:2. The use of *large objects* such as ovens inside an enclosure is known to have an adverse effect on performance and should be avoided if possible. If it is necessary to incorporate such equipment a full containment test should be arranged with the equipment in situ. It may be that alternative local exhaust ventilation devices are more appropriate for the contaminant release conditions presented by such equipment.

4:3:3. The apparatus within a cupboard must be configured to allow the operator the access necessary for normal attendance with the *sash in as low a position as is possible*. When using hotplates it may be necessary to use angled tongs for any manipulations if the combined height of the hotplate and beakers prevent the sash from being lowered to a level sufficient to provide splash protection. Suitable personal protective equipment must be worn, for example lab coats, gloves and face shields.

4:3:4. Under no circumstances should an experiment require an operator to position their *head* inside the cupboard enclosure at any time whilst hazardous substances are present.

4:3:5. The *structural rigidity* of any apparatus must be sufficient to withstand the likely stress present. Temporary configurations using adhesive tape and other short-term measures are not acceptable for even the shortest duration experiment.

4:3:6. Adequate *guarding* of hazards such as hot surfaces, moving machinery, or electrical conductors must be in place. Appropriate warning signs should be displayed.

4:4. Cupboard contents.

There may be occasions when maintenance staff or other persons not directly involved with the experiments need to know what substances are being released into the system. A *drywipe board* or other readily modified medium should be displayed near the fume cupboard, on which the hazardous substances currently being used can be recorded. In addition a *contact name* and internal telephone number should be provided. An *out-of-hours* number may be required if the substances are sufficiently hazardous to present major difficulties during-any plant failure, or if the experiment is likely to be adversely effected by a power failure or other unplanned event outside normal working hours.

4:5. Storage of materials in fume cupboards.

The storage of supply containers and other items will have an adverse effect on the airflow through the enclosure, and subsequently the containment performance of the system. The following rules must be adhered to at all times;

4:5:1. *Supply containers* stored in a fume cupboard enclosure must be limited to those materials currently being used in the experiment, and then must be limited to a maximum amount required for a single days work. If the supply container exceed the daily requirement it will be necessary to store them in an alternative location.

4:5:2. *Materials* other than those in current use should be stored in an alternative location, preferably in a suitable ventilated cupboard incorporating features to contain the volume of the spillage of the largest container held within.

4:5:3. *Storage cupboards* located below the enclosure can sometimes be ventilated by diverting some of the extracted force via a small (ie less than 50mm diameter) flexible hose connecting the cupboard space with a point on the ducting. Maximum benefit is achieved if the doors to the storage cupboard are perforated to allow make-up air to pass easily through.

4:5:4. NO *unnecessary equipment* such as hotplates or equipment stands should remain in a fume cupboard enclosure if they are not part of the experiment currently being conducted.

4:5:5. *Light-weight items* such as tissues, disposable gloves and filter-papers should be securely stored within the fume cupboard to prevent them being sucked through the enclosure as they become impacted around fan blades, causing subsequent loss of extract performance.

4:6. Pre-use operator checks.

Before the start of every day during which the fume cupboard is to be used, the operator (or a designated competent person from the laboratory) must complete a simple checklist to confirm the following basic functions of the system;

1. Operation of the on/off controls.
2. Operation of the sash mechanism.
3. Note the reading of a performance indicator (ie manometer) if fitted.
4. Operation of internal light.

The check will present the opportunity to note any deficiencies in the system performance, which should be recorded and brought to the attention of the supervisor as soon as possible. If subsequent daily checks show that fault has yet to be repaired the supervisor should be reminded, any further delay in repair should be brought to the attention of the site Safety Adviser

4:6:1. The record of this check must be signed and dated. An example record document is shown below, and should be displayed within close proximity of the cupboard at all times. Completed record sheets shall be achieved and be available for inspection by site Safety Advisers.

Fume cupboard Pre-use operators checklist. (Tick to confirm)

To be completed on EACH day that the fume cupboard is used.

Fume cupboard No			Location.			
Date	On/off	Sash	Flow indicator	Internal light	Fault conditions	Signed.

Part 5. Maintenance schedules.

A fume cupboard system will require regular examination and maintenance to ensure continued safe operation (I). This maintenance must be extended ALL parts of the system, and should be in the form of a programme of *planned preventative maintenance*.

5:1. Frequency of maintenance.

The primary legislative requirements are found in the Control of Substances Hazardous to Health (COSHH) Regulations (see Part 2), which require control measures used to prevent exposure to hazardous substances to be *maintained in an efficient state, in efficient working order and in good repair*. In addition *thorough examination and tests* must be carried out at least once every fourteen months. In practice this frequency of testing may be increased in accordance with the risk assessment of the effects of system failure. The schedule recommended in this code of practice includes elements at both six and twelve monthly intervals. Where system failures would result in significantly high risk of exposure it may be appropriate to halve the indicated intervals, or supplement them with additional measures. These examinations are additional to the pre-use operator checks.

5:2. Hazards during maintenance work.

It must be recognised that maintenance activities will present those undertaking them with them hazards other than those present during normal fume cupboard operations. It may be necessary to make separate *risk assessments* of the maintenance work, and to devise adequate *safe systems of work* which incorporate appropriate levels of competence, training, and supervision.

5:2:1. All work involving the interruption of normal fume cupboard operation's must be carried under the control of a *permit-to-work system*. An example of a permit to work is shown as appendix B.

5:2:2. Where maintenance work is carried out by *contractors* it is important to ensure that all relevant safety information is communicated between all parties. This might include the findings or risk assessments, details on substances used in the system, or any hazardous aspects of the maintenance work which might effect the laboratory or anyone working within it.

5:3. Record keeping.

Written records of maintenance work must be kept, including details of all repaired and replaced components. These records should be signed and dated by those responsible for the work.

5:4. Post maintenance performance testing.

It will be necessary to carry out testing following any maintenance work likely to influence the systems performance. This will include face velocity, containment, or engineering component testing. See part 6 of this code for further details.

Fume cupboard maintenance schedule.	Interval between maintenance.	
	Six Months.	Twelve months.
Enclosure.		
Visual examination to ensure integrity of enclosure, including seals around main panels, sinks and other services. Check storage voids underneath main aperture.	*	
Check operation of enclosure light.	*	
Replace enclosure light (ie fluorescent tube).		*
Controls.		
Activate on/off switch to confirm operation, and note operation of associated warning lights.	*	
Operate any other warning devices (ie sash height or low-flow switches) to confirm operation.	*	
Check air flow indicator device. In case of liquid manometer disconnect tubing and re-zero, then switch on fume cupboard and note movement of fluid column. Carry out face velocity checks	*	
Sash.		
Repeated movement of the sash through its entire travel to confirm ease of operation (lubricate where necessary).	*	
Operation of working aperture stop and over-ride mechanism.	*	
Check alignment of pulleys and condition of pulley wires, (replace any distorted or broken wire).		*
Inspect sash screen for cracks, chemical attack, or any other damage likely to adversely effect transparency of the screen.	*	

Fume cupboard maintenance schedule continued....	Interval between maintenance.	
	Six Months.	Twelve months.
Ducting.		
Examine fume cupboard-to-ductwork connection to confirm seal and physical condition.		*
Visual examination of entire ductwork run for mechanical damage and leaks, including internal sections where condensate or any other concentrations are likely to cause damage.		*
Mechanical volume flow control dampers should be inspected to confirm freedom of movement, and absence of internal obstruction.		*
Fire dampers examined for corrosion, and operated where possible.		*
Flow sensing devices, or any other equipment located within the ductwork should be examined and replaced if damaged.		*
Fan.		
Check flexible coupling (including tie-clips) to ductwork for damage, wear, or leakage.	*	
Visual examination of anti-vibration mountings.		*
Visual examination of all external features for mechanical integrity.	*	
Visual examination of <u>inside</u> the fan casing to confirm physical integrity, and absence from obstructions (ie tissues, rubber-gloves, filter papers).		*
Examination of electrical supply cables, switch-gear, connectors and isolators for physical damage and continued electrical operation.	*	
Check rigidity of exhaust stack.		*
Check condition and tension of drive belt, re-tighten or replace if necessary.	*	
Fit new drive belt.		*
Check drive-shaft bearings for excess movement or other signs of wear.		*
Re-grease bearings.		*
Lubricate electrical motor in accordance with manufacturers recommendations.		*

Part 6 : Fume cupboard performance testing.

Performance testing is necessary to confirm that the system and its individual engineering components are operating to a level necessary to provide the desired fume arrest, containment, and dispersal. It is appropriate in the following circumstances:

6:1. Frequency of testing.

COSHH regulation 9 established a duty on employers to carry out *thorough examination and test of engineering control measures* at least once every fourteen months. In cases where the risks associated with a particular experiment are high it will be necessary to increase the frequency of these examinations and tests. The decision on frequency can be determined by risk assessment, which should anticipate the likely outcome of a system failure.

Containment testing should be carried out

- as part of the *commissioning of new installations*,
- following major repairs or alterations to the fume cupboard or room

c) prior to the start of a high hazard process

6:2 Record keeping.

The regulations require that suitable records are produced, and these records are maintained for at least five years from the date of last test. The approved Code of Practice (ACOP) in support of COSHH establishes the test requirements, and has been used as a basis for the schedules recommended in this guidance. Example record documentation is given as appendix B.

6:3. Test principles.

In the past, fume cupboard performance has been monitored by measuring the rate at which air is drawn across the open aperture, this being known as *face velocity*, and a nominal range of acceptable values have been suggested by various sources usually between 0.5 - 1 meter per second. Research has shown that the mechanisms by which contaminants migrate across the aperture boundary are a function of complex aerodynamic conditions, and are not necessarily related to face velocity, making its measurements an unreliable indicator of performance. It is now generally accepted that a better indicator is the ability to arrest and retain a gaseous challenge released within the enclosure, the leakage being quantified by means of externally positioned detection devices, and referred to as *containment testing*.

In addition to the above measurements it is necessary to monitor the performance of the prime movers and other engineering components within the system, including the measurement of air velocity and pressure in ducting, and the speed and direction of fan impellers.

6:4. Instrumentation.

The equipment necessary to carry out the tests detailed in this section are available for use at NERC sites through the arrangements of the Safety Equipment Pool

6.5 Fume cupboard test procedures.

6:5:1. Containment test.

Equipment. Invent UK Ltd "Safecheck" test system- including Miran infra-red gas analyzer.

Objectives. To establish the containment performance of the system to enable direct comparison between systems and, in cases where more than one system is available, to allow fume cupboards to be more effectively matched with the hazards associated with specific hazardous substances and experiments. The cupboard can be tested either empty or inclusive of normal operating apparatus, the latter being more representative of operating conditions.

Method. A gaseous challenge of sulphur hexafluoride (SF₆) in nitrogen is injected into the enclosure at a precisely controlled rate to simulate the release of a contaminant within the cupboard. An array of sampling heads is positioned at the enclosure aperture and allowed to collect any SF₆ which is able to migrate across the boundary. Leakage is detected by means of an infra-red gas analyzer, connected to a PC which allows real-time display of the data as a trace of leakage (ppm) against time. The measurement is repeated with the array in six positions across the aperture.

Results. Containment performance is expressed as leakage of SF₆ in parts per million (ppm), both as a *mean* and an *instantaneous maximum* value. The values awarded to each cupboard are those corresponding to the worst of the six array positions. These values are then applied to the classification categories listed in table 1, which includes guidance on the limitations of use for the system in the light of its performance.

Full details of this test can be found in *Specifications handbook for fume cupboard performance tests: Procedures, requirements and gradings*. Invent UK Ref INV/92/12. See also EN141754.

Table1: Fume cupboard performance and classification:

Mean SF ₆ ppm	Max SF ₆ ppm	NERC Class	Substance hazard class (class A substances do not require a fume cupboard)	Notes
<0.005 – 0.020	<0.010 – 0.040	1	D/E	
0.021 – 0.10	0.041 – 0.2	2	C	

0.101 – 0.20	0.201 – 0.4	3	B	Carry out a survey to identify areas for improvement
>0.201	>0.40	4		Withdraw from use

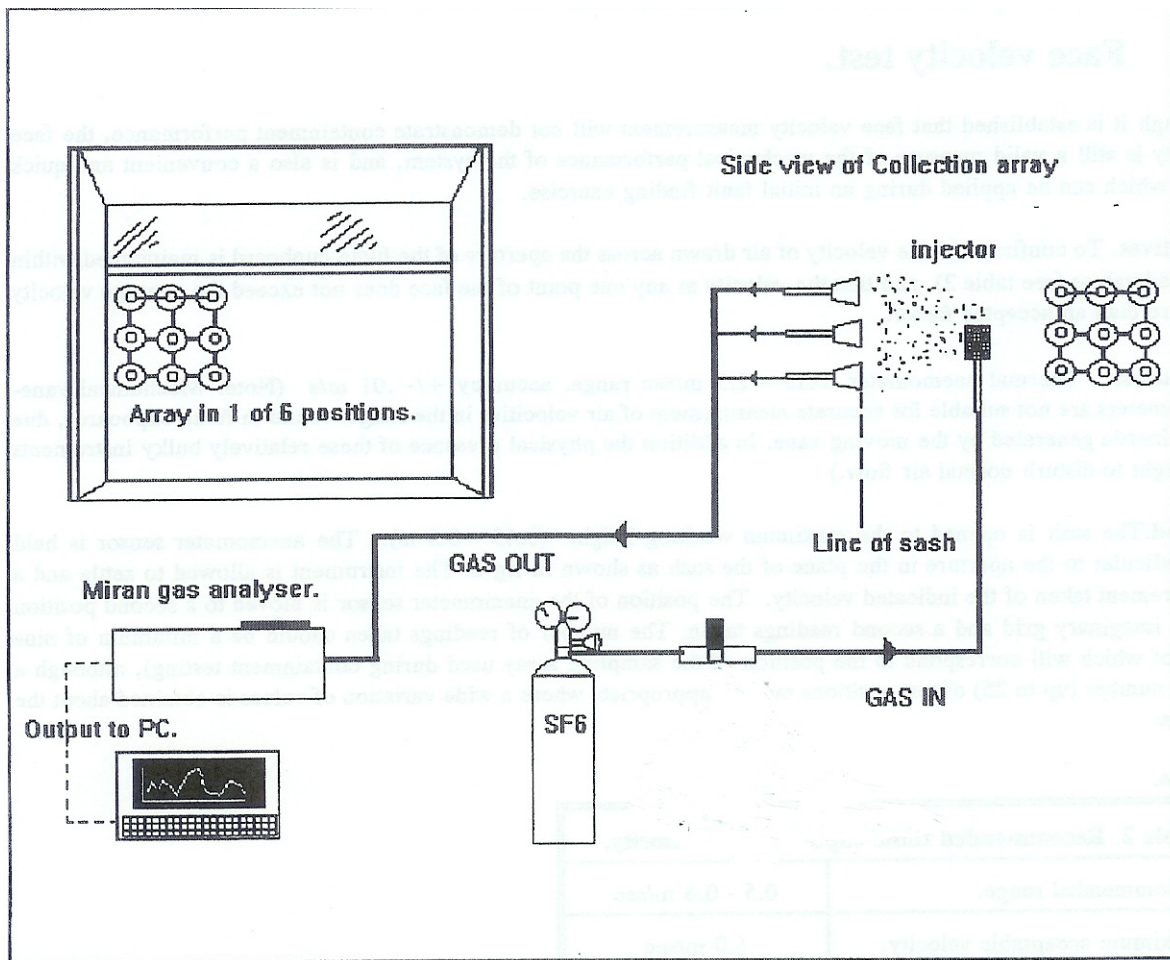

Figure 2 Safecheck containment test system (Invent UK Ltd).

Factors to consider when assessing containment test results.

- a) If a number of fume cupboard systems are present within a single laboratory it is desirable to match the fume cupboard with the best containment performance with the processes using the most hazardous substances.
- b) The NERC COSHH Procedure No. 19 and the NERC COSHH database software recommend the class of fume cupboard needed based on the inhalation hazard classification for particular substances.
- c) If containment performance is poor, particularly in specific areas of the aperture (eg. corners), adjustments should be made to any variable factors likely to effect performance. For example increasing/decreasing air flows, repositioning internal baffles, or the re-configuration of apparatus within the cupboard. In addition it is known that the retro-fitting of aerofoil sections along side edges of the enclosure, and to the bottom edge of the sash will increase containment performance.

6:5:2. Face velocity test.

Although it is established that face velocity measurement will not demonstrate containment performance, the face velocity is still a valid measure of the mechanical performance of the system, and is also a convenient and quick check which can be applied during an initial fault finding exercise.

Objectives. To confirm that the velocity of air drawn across the aperture of the fume cupboard is maintained within accepted values (see table 2), and that the velocity at anyone point of the face does not exceed the average velocity by more than an accepted factor.

Equipment. Thermal anemometer. 0.15 - 2.5 m/sec range, accuracy +/- .01 m/s (Note. Mechanical vane -

anemometers are not suitable for accurate measurement of air velocities in the ranges found in fume cupboards, due to the inertia generated by the moving vane. In addition the physical presence of these relatively bulky instruments is thought to disturb normal air flow.)

Method .The sash is opened to the maximum working height (0.45 - 0.5 m). The anemometer sensor is held perpendicular to the aperture in the plane of the sash as shown in fig 2. The instrument is allowed to settle and a measurement taken of the indicated velocity. The position of the anemometer sensor is moved to a second position on the imaginary grid and a second readings taken. The number of readings taken should be a minimum of nine (each of which will correspond to the position of the sampling array used during containment testing), although a higher number (up to 25) of test positions may be appropriate where a 'wide variation of values is obtained about the average.

Results.

Recommended range.	0.5 - 0.8 m/sec
Maximum acceptable velocity.	1.0 m/sec
Minimum acceptable velocity.	0.4 m/sec
Maximum deviation from mean velocity value of any other measurement within the grid.	+ / - 20%

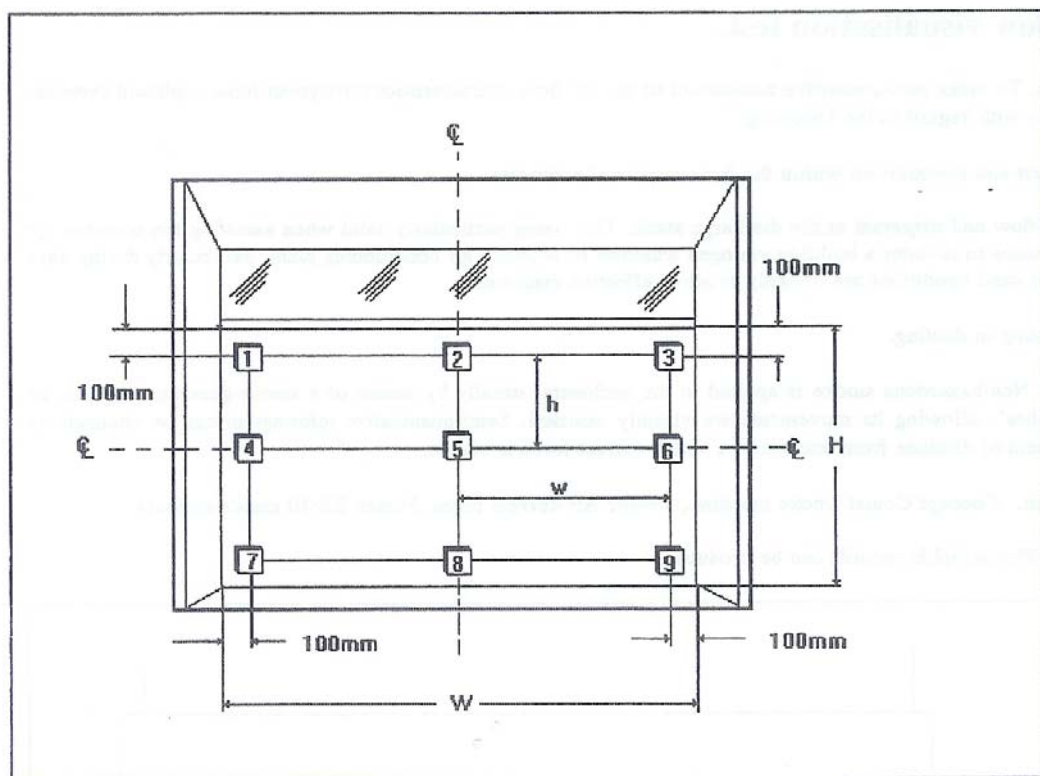

Face velocity measurement grid.

W= Sash width R= Sash Height set to 0.5m max. $w = (W - 200)/2$ $h = (H - 200)/2$

Figure 3

Factors to consider when assessing face velocity results.

- The range of acceptable values is open to debate. However in general the following generally accepted principles; i) *Face velocity too fast*. Velocities greater than 0.8 m/ s are likely to generate eddy currents around persons standing in front of the cupboard, and these are then able to draw contaminants out through the aperture, particularly during movement by the operator.
- Too slow*. It is unlikely that velocities below 0.4 m/s associated with older enclosures are able to arrest and contain contaminants within the enclosure, particularly where external air movements due to movement of staff or opening/closing of doors and windows are likely to exceed the face velocity. Modern enclosures may be designed to operate at lower velocities but effective containment must be demonstrated by an SF6

challenge.

b) Where fume cupboards are found to have face velocities which lie outside the recommended or acceptable values, steps must be taken to modify the system. Improvement measures include;

i) *Decrease or increase of velocity.* a) If a manually operated volume control damper (VCD) is fitted in the ducting of a system this can be closed down to reduce the airflow, or opened up to increase it. The fitting of VCDs is encouraged as they allow variable control within the system. b) Altering the ratio of motor-to-fan drive pulleys by fitting different diameter pulleys is an option on indirect drive configurations. On direct drive systems the motor speed has to be altered, either by electronic controller, or replacement with an alternative motor.

ii) *Increase only.* Where air flow is inadequate, and pulley changing will not achieve greater performance from the fan, it will be necessary to fit a fan and motor assembly capable of higher performance.

c) The effect on the performance of the system as a result of adjustments to the air flow rate should be assessed by subsequent testing.

6:5.3. Engineering measurements.

a) Air velocity and volume flow rate in ducting.

i) *direct velocity measurement* using a thermal anemometer, or ii) taking *velocity-pressure measurements* using a pitot static tube and pressure sensor inclined manometer, electronic manometer, or magnehelic gauge and subsequently converting pressures into velocity by calculation. The sensor has to be moved across the area of the duct in incremental steps.

Note. In circumstances where air temperature deviates significantly from 16°C (+/-2°) it will be necessary to incorporate suitable correction factors when measurements are taken.

Conversion to volume flow rates.

Velocities in ducting can be converted to volume flow rates by multiplying the average velocity by the cross sectional area of the duct.

$$\text{Ave velocity (m/sec)} \times \text{C.S.A (m}^2\text{)} = \text{Volume flow rate (m}^3\text{/sec)}$$

It is often convenient to convert this value into m³/hour, achieved by multiplying m³/sec by 3600.

b) Fan

i) Volume flow rate. Use same method and equipment as for measurement of flow in ducting.

ii) Static pressure at inlet and outlet. A pressure sensing device (fluid manometer, magnehelic gauge) is connected to a pre-existing port located on each side of the fan housing. Tubing is used to connect the port to the appropriate side of the gauge (positive or negative) and a reading is taken on each side. Typically the negative reading will be of greater magnitude than the positive, and will be in the range of 100 - 300 Pa.

iii) Velocity at discharge point (efflux velocity).

This is measured by positioning a velocity sensor in the flow at the point that it leaves the discharge stack. A mechanical displacement anemometer will be of sufficient sensitivity for this measurement.

Preferred range = 15 - 20 m/sec

Minimum = 10 m/sec.

See BS848:Part 1:1980

c) Speed & direction of rotation of fan & motor.

Use of either a *direct contact* or *optical tachometer* will give an indication of the rotational speed of the motor and fan shafts.

Visual inspection of markings on fan case to confirm correct direction of rotation. This is an important point to check because a fan running in the wrong direction will still move air, but much less efficiently. The direction of rotation can be unintentionally reversed by connecting the electrical supply wires incorrectly, so post maintenance checking is recommended.

Appendix A:

Recirculating and portable duct-less fume cupboards

This guidance covers the use of duct-less fume cupboard systems which draw air through an open enclosure, and pass it through a *replaceable molecular filter*, allowing expulsion back into the laboratory air for recirculation. The principle concerns regarding this type of equipment is that the filter elements have a *finite absorbent capacity*, which if exceeded can allow hazardous concentrations of contaminant to *breakthrough* the filter into the laboratory atmosphere.

For this reason the use of such a system should only be considered where ducted systems are not reasonably practicable, for example in temporary field laboratories. Use must only be permitted if a suitable risk assessment has been carried out taking into account the following recommendations;

- a) the *appropriate filter* must be selected for the substances to be used. Consideration must be given to the compatibility of substances.
- b) calculations must be made to establish the *release characteristics* of the contaminant, these should be applied to determine the maximum time the system can be used before exhausting the filter element. The likely date of exhaustion must be clearly displayed on the system, and communicated to staff using the system.
- c) a *system of work* must be devised to monitor the use of the system, for example the *actual* release of contaminant and duration of use. A record of the system use shall be maintained and made available for inspection by all staff likely to use the system.
- d) the system of work must consider the *handling and disposal of contaminated filter elements*, which are likely to be classified as special waste, and require appropriate disposal.

Appendix B:

Auxiliary air fume cupboards.

The fundamental design difference between these and standard fume cupboards is the use of air supplied into the enclosure at positive pressure to assist in the ventilation of contaminated air being extracted by a conventional negative pressure fan-set. The arrest of contaminant is achieved by a *scrubbing* motion caused by two *contra-rotating vortices*.

Whilst most of the procedures established by this code are valid for both standard and auxiliary air fume cupboards, the following points specific to the latter should be noted:

- a) Because the arresting mechanism is dependant upon the effective operation of *two* independent plant systems (extract and supply), it is important that *maintenance, examination and testing* is extended to all relevant equipment, particularly the *air handling unit* providing the supply air.
- b) The arresting motion is maintained by a curtain of supply air blown into the front of the enclosure via vents at the front and sides. This is unlikely to result in *face velocities* within the ranges traditionally considered as acceptable for standard fume cupboards, therefore face velocity can not be relied upon as a performance indicator. Air velocities and volume flow rates can be measured for both the supplied and extracted air, with system performance being confirmed by *containment testing* (See 6:5 of this code).

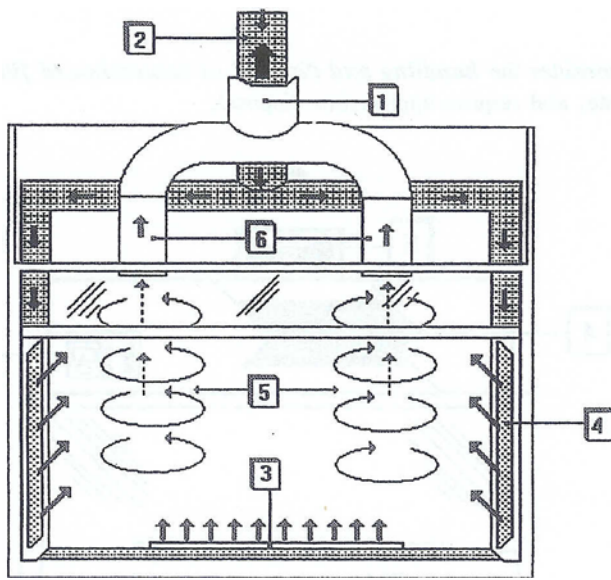

1) Extract air (OUT) 2) Supply air (IN) 3) Front supply vent 4) Side supply vent 5) Contra-rotating vortices 6) Extract ports in ceiling of enclosure.

Figure 4

Appendix C:

Wet scrubbed systems.

Fume cupboard systems used with high concentrations of corrosive substances (ie. perchloric and hydrofluoric acids) require the dilution of the contaminated airstream prior to discharge to reduce the environmental impact, and prevent damage to the system components. Dilution is achieved by directing the airstream through an enclosure incorporating a water spray, and optionally filter media. This enables the arrest (scrubbing) of the contaminant within the water stream, allowing the collection of waste within a sump, and ultimate discharge in diluted concentration via a suitable drain.

Failure of plant providing the water wash would result in unacceptable release of concentrated fumes, therefore it is necessary to make arrangements to ensure effective maintenance. In some cases it will be valid to provide emergency back-up, for example by incorporating a second water pump. *Planned preventative maintenance* and *regular examination and testing* of the scrubber system are recommended.

The efficiency of the system can be determined by monitoring the concentrations of contaminant within the airstream on both sides of the scrubbers by using Dräger tubes or similar detectors. Concentrations of contaminant within the liquid waste stream can be monitored using indicating papers. This will confirm compliance with relevant Water Authority consents to discharge via the drains.

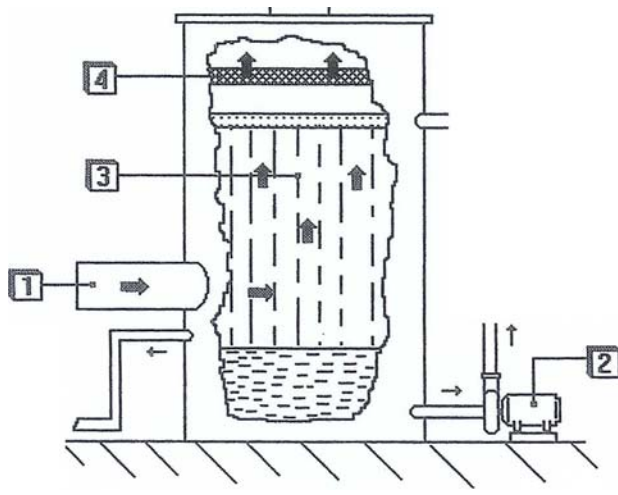

Figure 5

Key: 1. Airstream IN from fume cupboard enclosure: 2. Water circulation pump: 3. Shower: 4. Spray eliminator:
5. Airstream OUT to fan.

Appendix D:

Example documents

1. Record of examination and test of laboratory fume cupboard.
2. Fume cupboard pre-use operators checklist.

Record of examination and test of laboratory fume cupboard.

1. Equipment & Location.

FC Number.

Site:

Building:

Type:

Room:

Manf:

Date of last examination and test:

2. Process under control.

- 1.
- 2.
- 3.
- 4.

Hazardous substances present.

- 1.
- 2.
- 3.
- 4.

3. Conditions at time of test

- a) in service
 b) stood down
 c) other

d) indicate contents at time of test.

4. Examination & test details

a) Controls:

- i) Fan on/ off.
 ii) Enclosure light

Pass
Fail
N/A
Comments

b) Flow indicators:

- i) Electro/mechanical

 Light Audible warning

c) Enclosure:

- i) Sash operation
 ii) Sash Height warning.
 iii) Sash Height limiter
 iv) Transparency of sash

 Light Audible warning

d) Face velocity measurements.

Aperture width

m

Max sash Height

m

Aperture area

 m²

Sash Height during test

m

Mean velocity

m/sec

Vol flow rate

 m³/Hr

P1	P2	P3
P4	P5	P6
P7	P8	P9

 Instrument used. Thermal anemometer Vane anemometer

Notes: 1. Recommended 0.45 to 0.5m sash Height.

e) Containment test. (Using safecheck SF₆ gas challenge)

Record file names:

NERC

Classification

1	Mean SF6	Max SF6	<input type="checkbox"/>
2	0.005-0.020	0.010-0.040	<input type="checkbox"/>
3	0.021-0.100	0.041-0.200	<input type="checkbox"/>
4	0.101-0.200 >0.201	0.201-0.400 >0.400	<input type="checkbox"/>

SF₆ Concentrations.

P1 Mean	P2 Mean	P3 Mean
Max	Max	Max
P4 Mean	P5 Mean	P6 Mean
Max	Max	Max

- 1) See NERC "Safe use, maintenance and testing of laboratory fume cupboards (Part 6)" for further details.
- 2) Use permit-to-work systems when interrupting normal FC operations.

Record of examination and test of laboratory fume cupboard (cont).

f) Ducting measurements.

Diameter	m	Temp in duct	°C
Velocity pressure	Pa	Transport Velocity	m/sec
Volume flow rate	m ³ /hr	Measurements by Thermal anemometer <input type="checkbox"/>	Pitot-tube <input type="checkbox"/>

Visual inspection.	Pass	Fail	Comments
i) Mechanical integrity.	<input type="checkbox"/>	<input type="checkbox"/>	
ii) Condition of seals & vibration dampers.	<input type="checkbox"/>	<input type="checkbox"/>	
iii) Condition of volume control dampers.	<input type="checkbox"/>	<input type="checkbox"/>	
iv) Operation of fire dampers.	<input type="checkbox"/>	<input type="checkbox"/>	

g) Fan

Type:	Centrifugal. <input type="checkbox"/>	Serial Number:	<input style="width: 90%;" type="text"/>
	In-line radial. <input type="checkbox"/>	Direction of rotation marked: CW <input type="checkbox"/>	ACW <input type="checkbox"/>
	Bifurcated <input type="checkbox"/>	Motor details:	<input style="width: 80%;" type="text"/>

Static pressure IN Pa (-) <input style="width: 80%;" type="text"/>	Static P OUT Pa (+) <input style="width: 80%;" type="text"/>	Efflux velocity m/sec <input style="width: 80%;" type="text"/>
--	--	--

Visual Inspection.	Pass	Fail	Comments.
i) Inside impeller clear of debris	<input type="checkbox"/>	<input type="checkbox"/>	
ii) Impeller blades intact	<input type="checkbox"/>	<input type="checkbox"/>	
iii) Drive belt.	<input type="checkbox"/>	<input type="checkbox"/>	
iv) Mechanical parts (integrity & corrosion)	<input type="checkbox"/>	<input type="checkbox"/>	
v) Electrical system (as above)	<input type="checkbox"/>	<input type="checkbox"/>	

5. Report, repairs and corrective maintenance requirements.

Fault	Action	Date completed
1.	1.	
2.	2.	
3.	3.	
4.	4.	
5.	5.	
6.	6.	
Further comments:		

6. Details of person carrying out examination and test.

Name:	Designation:
Date of test:	Signature:

The COSHH Regulations require that management ensure that the Emergency Services are aware of hazards and risks posed to their personnel attending an emergency on NERC sites. This would normally apply to the Fire Service. Absolute guidance on how to meet these requirements cannot be given since different Fire Services operate different schemes and procedures. Most Fire Services will ask local management for information and will specify how they want the information provided. Some operate their own "Hazchem" systems and will label buildings, or parts of buildings, with their own signs to indicate hazard. All NERC sites should have complete drawings of their buildings on a CAD (computer aided design) system; these can be used to identify locations of hazardous chemicals. The NERC COSHH software has provision for local management to identify locations on site where chemicals are stored and used; this can be searched in terms of specific R Phrases and reports generated on location of, for example, flammables or reproductive toxins. If your local Fire Service has not been in contact with you and asked for the relevant information, contact the Fire Authority in your area and ask about how you should provide it.

APPENDIX VIII: SOURCES OF EXTRA INFORMATION

General COSHH Approved Code of Practice and Carcinogens ACOP HSE Books 1999

COSHH Essentials HSE Books 1998

Technical basis for COSHH essentials: easy steps to control chemicals HSE Books 1999

Respiratory sensitisers and COSHH; Breath Freely HSE leaflet

**All of the above can be downloaded from the Technical Indexes system via the web;
contact your local Safety Adviser for details of how to access the website.**